

# MEZUZA

## INTRODUCTION TO MEZUZA

### Introduction to Mezuzah

A mezuzah (pl., mezuzot) is a small, sofer-inscribed parchment scroll containing the two Torah paragraphs commanding us to put mezuzot on our doorposts and gates: Deuteronomy/Devarim 6:4-9 and 11:13-21 (these are the first two paragraphs of the shema prayer.) Each doorway that is related to where people live must have a mezuzah.

Mezuzot are placed on the right side of doorways as you enter in apartments, buildings, or even recreational vehicles that you rent for 30 days or more (or that you purchase/own), in which you sleep.

A mezuzah has protective value in that it reminds us to think about God each time we walk past a doorway or gateway, and so the particular name of God written on the mezuzah (shin-daled-yud) likewise can serve as an acronym for God's role as "Shomer dirot Yisrael"—Watcher over the dwelling places of Israel.

## MEZUZA: PARTS

### Mezuzah: God's Name on Outside

A mezuzah scroll should be rolled from left to right so that God's name appears on the outside.

### Mezuzah: Covers

Mezuzot are not required by halacha to have covers (sheitels). Covers are only for decorating and protecting the parchment; their use is recommended in the Shulchan Aruch.

**NOTE** Covers may be necessary to protect the mezuzot where the weather is humid, hot, or rainy.

## MEZUZA: WHICH BUILDINGS REQUIRE

### Mezuzah: Where People Live

Only buildings in which people live need a mezuzah, so you do not need to put them on offices, synagogues, or stores (unless people also live there). No mezuzah is needed on an eruv.

### Mezuzah: Buildings Regularly Used with a Person's Home

Mezuzot must be placed on any buildings used with a person's home.

#### EXAMPLES

- A barn with animals that is near a house, if you use their milk or meat for food.
- A coop with birds that is near a house if you eat their meat or eggs.
- A shed for firewood.

**NOTE** There may be exceptions due to size or other factors--consult a rabbi.

**NOTE** A structure that only stores items not used regularly, such as a shed for storing a sukka--even if attached to a house--does not need a mezuzah.

**NOTE** Do not put mezuzas on a sukka or any other temporary structure. If you have a pergola or gazebo that is at least 50 sq. ft. of area inside and that you use during much of the year, consult a rabbi.

### Mezuzah: Hotel Rooms

We do not normally affix mezuzot to hotel rooms, even when we would be required to (as when staying for more than 30 days).

**REASON** To do so might damage the hotel property.

**WHAT TO DO** Do not affix a mezuzah even with long-lasting tape.

**NOTE** You may not affix a mezuzah if you will not be allowed to remove it when you leave.

## MEZUZA: WHICH DOORS

### Mezuzah: Which Doors: All Doors Except...

Each door needs a mezuzah except for a:

- Bathroom, or a
- Room less than 50 square feet.

**NOTE** Do not affix a mezuzah to a door that is sealed closed.

### Mezuzah: Which Doors: Balcony

Any covered balcony over 50 square feet requires a mezuzah.

### Mezuzah: Which Doors: Arches

Place a mezuzah on doors or gates, even if they have an arch on top instead of a straight lintel.

## MEZUZA: PLACEMENT

### Mezuzah: Placement: Right Side of Doorway

Attach a mezuzah to the right side of the doorway as you follow the main traffic through the house. If there is one continuous path to go further into the house, place all of the mezuzot on the right side as you go further into the house.

### Mezuzah: Placement: Balcony

Place a balcony door mezuzah on the right side of the doorway as you enter the house from the balcony, if the balcony has an outside entrance. If the balcony does not have an outside entrance, put the mezuzah on the right side as you exit the house.

**NOTE** If the balcony has a roof, you may be able to put it on the right side as you go out. Consult a rabbi.

### Mezuzah: Placement

#### Mezuzah: Placement: Door Frame

Place the mezuzah outside the door but within the door frame. If not possible, you may place the mezuzah inside the door frame.

**NOTE** You may recess a mezuzah into the door frame.

**NOTE** If the doorframe is wider than 4" (10 cm), place the mezuzah toward the outer edge of the frame, not centered in the middle.

**NOTE** You may attach a mezuzah to a piece of wood that extends the doorway.

#### Mezuzah: Placement: Height

Place the mezuzah at shoulder height for the average person. Leave at least one tefach (4", or 10 cm) between mezuzah and lintel.

If possible, affix a mezuzah just above where the top 1/3 of the doorpost meets the middle 1/3.

**NOTE** This rule is superseded by the rule that the mezuzah must be near shoulder height.

#### Mezuzah: Placement: Angle

Place the mezuzah on a 45-degree angle from the vertical, with the top of the mezuzah toward the inside of the main room. If you cannot, any angle toward the entrance is OK.

## Mezuzah

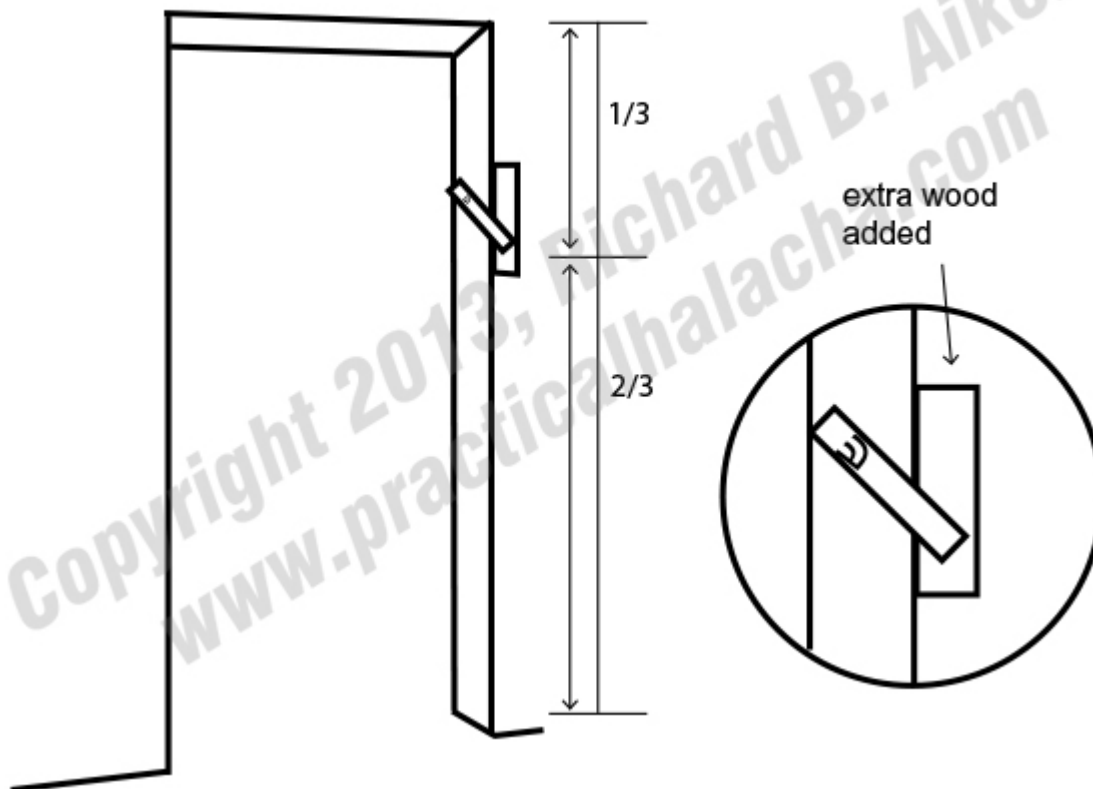

### MEZUZA: WHEN TO AFFIX

### MEZUZA: WHEN TO AFFIX IN ERETZ YISRAEL

#### Mezuzah: When To Affix in Eretz Yisrael

In Eretz Yisrael, whether you buy or rent, you must affix mezuzot immediately upon moving in.

### MEZUZA: WHEN TO AFFIX OUTSIDE ERETZ YISRAEL

#### Mezuzah: When To Affix Outside Eretz Yisrael: Buying (or Renting for More Than 30 Days)

Outside of Eretz Yisrael, you must affix a mezuzah immediately once you begin "living" in your house--determined by the first time you eat or sleep in the house. If you buy a house but do not move in immediately (for any reason--repairs, you are still in your previous house, etc.), you should affix a mezuzah but do not say the blessing. Then, when you do move in, remove the mezuzah and re-affix it and say the blessing.

You need not affix a mezuzah if you will be renting for less than 30 days, and you may delay putting up a mezuzah until the 30th day if you will be renting longer than that. Here are the types of rentals that will require a mezuzah by the 30th day:

- A home,
- An apartment, or
- Other accommodation--such as a camper, trailer, recreational vehicle (RV), etc.--in which you will live at some time.

**NOTE** If you are renting a vehicle/trailer that you will live in but might not keep it for 30 days, put on mezuzas as needed immediately but do not say a blessing (this is the same for in Eretz Yisrael or outside). Then, even if you keep it for more than 30 days, do not do anything additional (don't remove them and replace; don't say a blessing).



If you live in a vehicle for more than 30 days, you must affix mezuzas next to each of the doors.

### **Mezuzah: When To Affix Outside Eretz Yisrael: Renting for Fewer Than 30 Days**

Outside of Eretz Yisrael, you do not need to affix a mezuzah (even without a blessing) to an apartment, house, or other accommodation that you rent for less than 30 days.

### **Determining 30-Day Mezuzah-Affixing Period**

If you are living in a rented house, apartment, RV, etc., and remove all of your possessions used for living (such as clothing, bedding, and toiletries) at some time before 30 days have elapsed, the place is not considered to be your domicile. You restart counting the 30 days from the day you move the personal items back inside.

**SITUATION** You rent a vehicle for 30 or more days but live and sleep there only five days a week (and remove all your personal items to spend Fridays and Shabbats with a family or in a hotel)

**WHAT TO DO** You will not be considered to be living there; you must affix a mezuzah only if you leave some personal effects in the vehicle continuously for at least 30 days.

## **MEZUZA: BLESSING**

### **Mezuzah: Blessing**

When you attach a mezuzah to the correct doorpost, affix it at the bottom first and then say the blessing likbo'a mezuzah.

**NOTE** Do not say the blessing if there is no door in the doorway

### **Mezuzah: Blessing If Mezuzah Falls Off**

Say the blessing again when you replace a mezuzah that falls off.

### **Mezuzah: Blessing If You Removed Mezuzah**

Don't say a new blessing when you replace a mezuzah that you took off (for example, to have it checked).

## **MEZUZA: KISSING**

### **Mezuzah: Kissing: Custom**

Kissing a mezuzah (and tefilin) is not halacha but rather a custom to show our love for those mitzvot.

### **Mezuzah: Kissing: Which To Kiss**

If your custom is to kiss mezuzot, only kiss them when entering or leaving a house. Do not kiss the mezuzot on the interior room doorways.

## **MEZUZA: CHECKING**

### **Mezuzah: Checking: How Often**

Have your mezuzot checked twice every seven years.

## **MEZUZA: BEDROOM**

### **Mezuzah: Bedroom**

You may not be naked or have intercourse in a room with a mezuzah inside the room, unless:

1. There is a wall or divider within 10.5 inches of the ground and at least 40 inches tall between yourself and the mezuzah, or
2. The mezuzah is covered by two layers (kis b'toch kis) of paper or other material.

**NOTE** This is true even if the couple is covered, as is the proper practice, and even if they are more than 4 amot/7 feet away, since the entire room is considered to be one domain.

## **MEZUZA: REMOVAL**

### **Mezuzah: Removal: Do Not Remove When...**

Do not remove your mezuzot if you:

- Leave your house, even for a long period such as a year.
- Sell your house to a Jew.